

Professional high-speed optical transceiver

OPN-SG15-180LC2 / OPN-SG15-180LC2I

3.3V / 1550 nm / 1.25 Gbps Digital Diagnostic LC SFP SINGLE-MODE TRANSCEIVER

PRODUCT FEATURES

- Hot-Pluggable SFP Footprint LC Optical Transceiver
- Small Form-Factor Pluggable (SFP) MSA compatible
 - Compliant with IEEE 802.3z Gigabit Ethernet
- Compliant with Fiber Channel 1X SM-LC-L FC-PI
 - SFF-8472 Digital Diagnostic Function
 - 1550 nm DFB LD Transmitter
 - APD High Sensitivity Receiver
 - 39 dB Power Budget at Least
 - Distance up to 180 km
 - AC/AC Coupling according to MSA
 - Single +3.3 V Power Supply
 - RoHS Compliant
- 0 to 70°C Operation: OPN-SG15-180LC2
- -50 to 85°C Operation: OPN-SG15-180LC2I
- Class 1 Laser International Safety Standard IEC-60825Compliant

APPLICATIONS

- Gigabit Ethernet Switches and Routers
- Fiber Channel Switch Infrastructure
 - XDSL Applications
 - Metro Edge Switching

PRODUCT DESCRIPTION

The OPN-SG15-180LC2 series single mode transceivers are small form factor pluggable module for bi-directional serial optical data communications such as Gigabit Ethernet 1000BASE-ZX and Fiber Channel 1x SM-LC-L FC-PI. It is with the SFP 20-pin connector to allow hot plug capability. Digital diagnostic functions are available via an I²C. This module is designed for single mode fiber and operates at a nominal wavelength of 1550 nm. A guaranteed minimum optical link budget of 39 dB is offered which can correspond to a link distance of over 160 km (assuming worst case fiber loss of 0.2 dB/km). The transmitter section uses a multiple quantum well 1550 nm DFB laser and is a class 1 laser compliant according to International Safety Standard IEC-60825. The receiver section uses an integrated InGaAs Avalanche photodetector preamplifier mounted in an optical header and a limiting post-amplifier IC.

ORDER INFORMATION

| P/No. | Bit Rate (Gb/s) | 1000 BASE | Distance (km) | Wavelength (nm) | Package | Temp. (°C) | TX Power (dBm) | RX Sens. (dBm) | RoHS Compliant |
|------------------|-----------------|-----------|---------------|-----------------|-----------------|------------|----------------|----------------|----------------|
| OPN-SG15-180LC2 | 1.25/1.063 | | 180 | 1550 DFB | LC SFP with DMI | 0 to 70 | 6 to 3 | -36 | Yes |
| OPN-SG15-180LC2I | 1.25/1.063 | | 180 | 1550 DFB | LC SFP with DMI | -50 to 85 | 6 to 3 | -36 | Yes |

| Absolute Maximum Ratings | | | | | |
|----------------------------|--------|------|-----|-------|-------------------------------------|
| Parameter | Symbol | Min | Max | Units | Notes |
| Storage Temperature | Tstg | -50 | 85 | °C | |
| Operating Case Temperature | Topr | 0 | 70 | °C | OPN-SG15-180LC2 OPN-SG15-180LC2I |
| Power Supply Voltage | Vcc | -0.5 | 3.6 | V | |

Professional high-speed optical transceiver

| Recommended Operating Conditions | | | | | | |
|----------------------------------|------------------------|----------|------|----------|---|--|
| Parameter | Symbol | Min | Typ | Max | Units / Notes | |
| Power Supply Voltage | V _{cc} | 3.13 | 3.3 | 3.47 | V | |
| Operating Case Temperature | T _{opr} | 0 -50 | | 70 85 | °C / OPN-SG15-180LC2 °C / OPN-SG15-180LC2I | |
| Power Supply Current | I _{CC(TX+RX)} | | 230 | 280 | mA | |
| Data Rate | | | 1250 | | Mb/s | |

| Transmitter Specifications (0°C < T _{opr} < 70°C, 3.13V < V _{cc} < 3.47V) | | | | | | |
|---|-----------------------------------|------|------|----------------------|-------|---------------------|
| Parameter | Symbol | Min | Typ | Max | Units | Notes |
| Optical | | | | | | |
| Optical Transmit Power | P _o | 3 | --- | 6 | dBm | 1 |
| Output Center Wavelength | λ | 1520 | 1550 | 1580 | nm | |
| Output Spectrum Width | Δλ | --- | 0.2 | 1 | nm | -20 dB Width |
| Side Mode Suppression Ratio | SMSR | 30 | | | dB | |
| Extinction Ratio | E _R | 9 | --- | --- | dB | |
| Optical Rise Time | t _r | | | 260 | ps | 20 % to 80% Values. |
| Optical Fall Time | t _f | | | 260 | ps | 20 % to 80% Values. |
| Relative Intensity Noise | RIN | | | -120 | dB/Hz | |
| Electrical | | | | | | |
| Data Input Current – Low | I _{IL} | -350 | | | μA | |
| Data Input Current – High | I _{IH} | | | 350 | μA | |
| Differential Input Voltage | V _{IH} - V _{IL} | 0.5 | | 2.4 | V | Peak-to-Peak |
| TX Disable Input Voltage – Low | T _{DIS, L} | 0 | | 0.5 | V | 2 |
| TX Disable Input Voltage – High | T _{DIS, H} | 2.0 | | V _{cc} | V | 2 |
| TX Disable Assert Time | T _{ASSERT} | | | 10 | μs | |
| TX Disable Deassert Time | T _{DEASSERT} | | | 1 | ms | |
| TX Fault Output Voltage -- Low | T _{FaultL} | 0 | | 0.5 | V | 3 |
| TX Fault Output Voltage -- High | T _{FaultH} | 2.0 | | V _{cc} +0.3 | V | 3 |

1. Output power is power coupled into a 9/125 μm single mode fiber.
2. There is an internal 4.7K to 10K ohm pull-up resistor to V_{cc}TX.
3. Open collector compatible, 4.7K to 10K ohm pull-up to V_{cc} (Host Supply Voltage).

| Receiver Specifications (0°C < T _{opr} < 70°C, 3.13V < V _{cc} < 3.47V) | | | | | | |
|--|-----------------------------------|------|-----|----------------------|-------|-------------------------|
| Parameter | Symbol | Min | Typ | Max | Units | Notes |
| Optical | | | | | | |
| Sensitivity | Sens | | | -36 | dBm | 4 |
| Maximum Input Power | P _{in} | -10 | | | dBm | 4 |
| Signal Detect -- Asserted | P _a | --- | | -36 | dBm | Transition: low to high |
| Signal Detect -- Deasserted | P _d | -50 | --- | --- | dBm | Transition: high to low |
| Signal detect -- Hysteresis | | 1.0 | --- | | dB | |
| Wavelength of Operation | | 1100 | --- | 1600 | nm | |
| Electrical | | | | | | |
| Differential Output Voltage | V _{OH} - V _{OL} | 0.6 | | 2.0 | V | |
| Output LOS Voltage -- Low | V _{OL} | 0 | | 0.5 | V | 5 |
| Output LOS Voltage -- High | V _{OH} | 2.0 | | V _{cc} +0.3 | V | 5 |

4. Measured at 2⁻¹-1 PRBS at BER 1E-12. Receiver sensitivity is better than -36dBm at 1.25 Gbps. However, due to the resolution limitation of Digital Diagnostic Monitoring, the effect readout range for the RX received power at EEPROM A2 is from -10 to -34 dBm.
5. Open collector compatible, 4.7K to 10K ohm pull-up to V_{cc} (Host Supply Voltage).

Professional high-speed optical transceiver

CONNECTION DIAGRAM

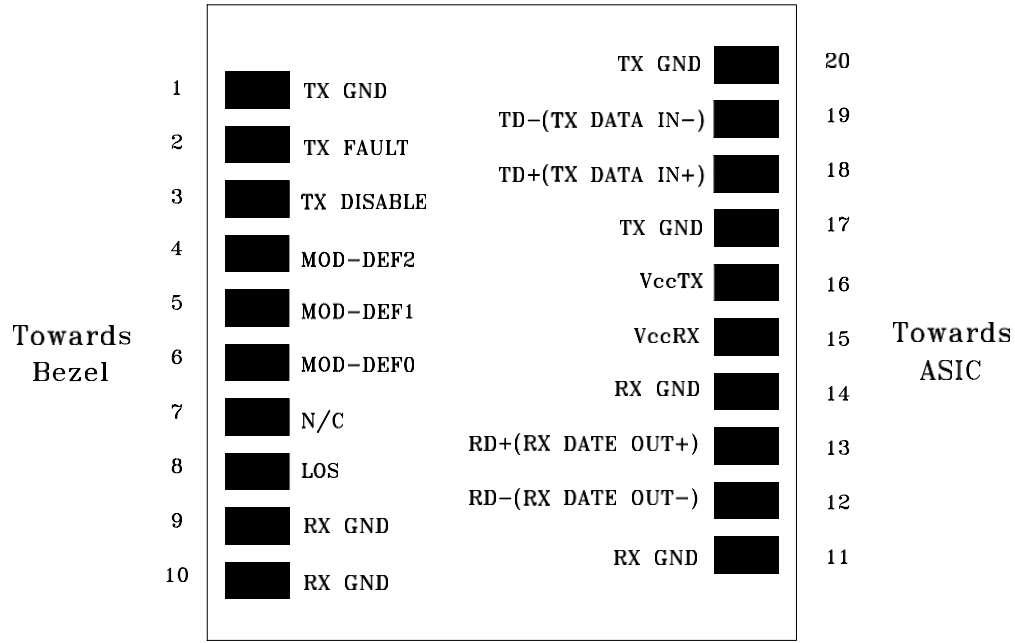

| PIN | Signal Name | Description | PIN | Signal Name | Description |
|-----|-------------|---|-----|--------------|-----------------------------|
| 1 | TX GND | Transmitter Ground | 11 | RX GND | Receiver Ground |
| 2 | TX Fault | Transmitter Fault Indication | 12 | RX DATA OUT- | Inverse Receiver Data Out |
| 3 | TX Disable | Transmitter Disable (Module disables on high or open) | 13 | RX DATA OUT+ | Receiver Data Out |
| 4 | MOD-DFE2 | Modulation Definition 2 – Two wires serial ID Interface | 14 | RX GND | Receiver Ground |
| 5 | MOD-DEF1 | Modulation Definition 1 – Two wires serial ID Interface | 15 | Vcc RX | Receiver Power – 3.3V±5% |
| 6 | MOD-DEF0 | Modulation Definition 0 – Ground in Module | 16 | Vcc TX | Transmitter Power – 3.3V±5% |
| 7 | N/C | Not Connected | 17 | TX GND | Transmitter Ground |
| 8 | LOS | Loss of Signal | 18 | TX DATA IN+ | Transmitter Data In |
| 9 | RX GND | Receiver Ground | 19 | TX DATA IN- | Inverse Transmitter Data In |
| 10 | RX GND | Receiver Ground | 20 | TX GND | Transmitter Ground |

Module Definition

| Module Definition | MOD-DEF2 PIN 4 | MOD-DEF1 PIN 5 | MOD-DEF0 PIN 6 | Interpretation by Host |
|-------------------|-------------------|-------------------|-------------------|-----------------------------------|
| 4 | SDA | SCL | LV-TTL Low | Serial module definition protocol |

Module Definition 4 specifies a serial definition protocol. For this definition, upon power up, MOD-DEF(1:2) appear as no connector (NC) and MOD-DEF(0) is TTL LOW. When the host system detects this condition, it activates the serial protocol. The protocol uses the 2-wire serial CMOS E²PROM protocol of the ATMEL AT24C01A/02/04 family of components.

Professional high-speed optical transceiver

RECOMMENDED CIRCUIT SCHEMATIC

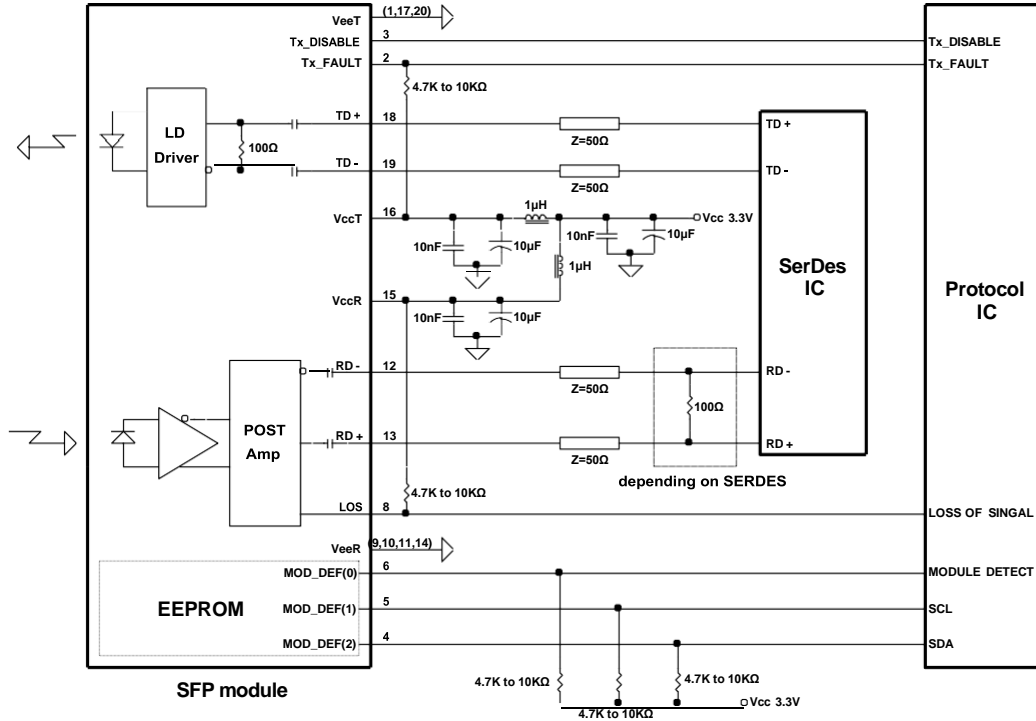

PACKAGE DIAGRAM

Units in mm

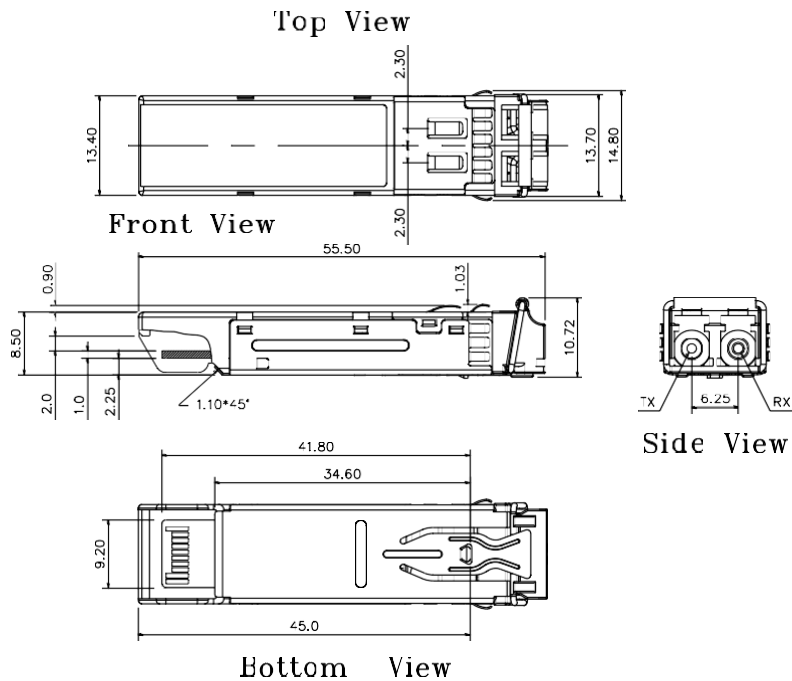

Note: Specifications subject to change without notice.