

Professional high-speed optical transceiver

**OPN-S8F1513-20SC / OPN-S8F1513-20SCI /
OPN-S8F1513P-20SC / OPN-S8F1513P-20SCI**

1550 nm TX / 1310 nm RX , 3.3V / 622 Mb/s RoHS Compliant Single-Fiber Transceiver

PRODUCT FEATURES

- Single Fiber Bi-Directional Transceiver
 - 1550 nm DFB LD Transmitter
 - 1310 nm Receiver
 - Distance up to 20 km
 - Industry Standard 1 x 9 Footprint
 - Single +3.3 V Power Supply
 - Speed up to 650 Mb/s
 - RoHS Compliant
 - PECL Differential Inputs and Outputs
 - 0 to 70°C Operating Temperature: OPN-S8F1513P-20SC
 - -50 to 85°C Operating Temperature: OPN-S8F1513P-20SCI
 - Wave Solderable
- Class 1 Laser International Safety Standard IEC-60825 Compliant

APPLICATIONS

- WDM 622 Mb/s Links
- SONET / SDH Equipment Interconnect

PRODUCT DESCRIPTION

The OPN-S8F1513P-20SCI series are high performance modules for single fiber communications by using 1550 nm DFB LD transmitter and 1310 nm receiver. The transmitter section uses a multiple quantum well laser and is a class 1 laser compliant according to International Safety Standard IEC-60825. The receiver section uses an integrated 1310 nm detector preamplifier (IDP) mounted in an optical header and a limiting post-amplifier IC. A PECL logic interface simplifies interface to external circuitry.

ORDER INFORMATION

P/No.	Bit Rate (Mb/s)	Distance (km)	TX (nm)	RX (nm)	Voltage(V)	Package	Temp. (°C)	TX Power (dBm)	RX Sens. (dBm)	RoHS Compliant
OPN-S8F1513P-20SC	622	20	1550 DFB	1310	3.3	1X9	0 to 70	-8 to -14	-28	Yes
OPN-S8F1513P-20SCI	622	20	1550 DFB	1310	3.3	1X9	-50 to 85	-8 to -14	-28	Yes

Absolute Maximum Ratings

Parameter	Symbol	Min	Max	Units	Notes
Storage Temperature	Tstg	-50	85	°C	
Operating Temperature	Topr	0 -50	70 85	°C	OPN-S8F1513P-20SC OPN-S8F1513P-20SCI
Soldering Temperature	---		250	°C	10 seconds on leads only
Power Supply Voltage	Vcc	0	3.6	V	
Input Voltage	---	GND	Vcc	V	
Output Current	Iout	0	30	mA	

Professional high-speed optical transceiver

Recommended Operating Conditions					
Parameter	Symbol	Min	Typ	Max	Units / Notes
Power Supply Voltage	Vcc	3.13	3.3	3.47	V
Operating Temperature	Topr	0 -50		70 85	°C / OPN-S8F1513P-20SC °C / OPN-S8F1513P-20SCI
Data Rate		50	622	650	Mb/s
Power Supply Current	Icc			260	mA

Transmitter Specifications (0°C < Topr < 70°C, 3.13V < Vcc < 3.47V)						
Parameter	Symbol	Min	Typ	Max	Units	Notes
Optical						
Optical Transmit Power	Po	-14	---	-8	dBm	1
Output Center Wavelength	λ	1480		1580	nm	
Output Spectrum Width	$\Delta\lambda$	---	---	1	nm	-20 dB Width
Extinction Ratio	ER	8.2	---	---	dB	
Output Eye	Compliant with Bellcore GR-253-CORE and ITU recommendation G.957					
Optical Rise Time	tr			1.2	ns	10% to 90% Values
Optical Fall Time	tf			1.2	ns	10% to 90% Values
Relative Intensity Noise	RIN			-116	dB/Hz	
Total Jitter	TJ			0.55	ns	2
Electrical						
Data Input Current – Low	IIL	-350			μ A	
Data Input Current – High	IiH			350	μ A	
Differential Input Voltage	V _{IH} - V _{IL}	300			mV	
Data Input Voltage – Low	V _{IL} - V _{CC}	-2.0		-1.58	V	3
Data Input Voltage -- High	V _{IH} - V _{CC}	-1.1		-0.74	V	3

- Notes: 1. Output power is power coupled into a 9/125 μ m single mode fiber.
 2. Measured with a 2²³-1 PRBS with 72 ones and 72 zeros.
 3. These inputs are compatible with 10K, 10KH and 100K ECL and PECL inputs.

Receiver Specifications (0°C < Topr < 70°C, 3.13V < Vcc < 3.47V)						
Parameter	Symbol	Min	Typ	Max	Units	Notes
Optical						
Sensitivity	---	---	---	-28	dBm	1
Maximum Input Power	Pin	-8		---	dBm	
Signal Detect -- Asserted	Pa	---	---	-28	dBm	Transition: low to high
Signal Detect -- Deasserted	Pd	-38	---	---	dBm	Transition: high to low
Signal detect -- Hysteresis		1.0	---		dB	
Wavelength of Operation		1260	---	1360	nm	2
Electrical						
Data Output Voltage – Low	V _{OL} - V _{CC}	-2.0		-1.58	V	3
Data Output Voltage – High	V _{OH} - V _{CC}	-1.1		-0.74	V	3
SD Output Voltage -- Low	V _{OL} - V _{CC}	-2.0		-1.58	V	3
SD Output Voltage -- High	V _{OH} - V _{CC}	-1.1		-0.74	V	3

- Notes: 1. Minimum sensitivity and saturation levels at BER=1E-10 for a 2²³-1 PRBS with 72 ones and 72 zeros.
 2. At least 30 dB optical isolation for the wavelength 1480 to 1580 nm.
 3. These outputs are compatible with 10K, 10KH and 100K ECL and PECL outputs.

Professional high-speed optical transceiver

CONNECTION DIAGRAM

Receiver Signal Ground
 Receiver Data Out
 Receiver Data Out Bar
 Signal Detect
 Receiver Power Supply
 Transmitter Power Supply
 Transmitter Data In Bar
 Transmitter Data In
 Transmitter Signal Ground

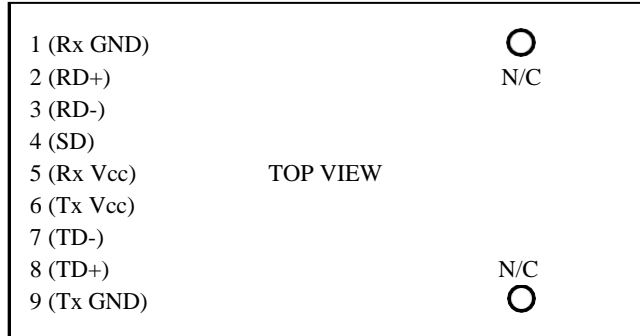

PIN	Symbol	Notes
1	Rx GND	Directly connect this pin to the receiver ground plane
2	RD+	See recommended circuit schematic
3	RD-	See recommended circuit schematic
4	SD	Active high on this indicates a received optical signal
5	Rx Vcc	+3.3V dc power for the receiver section
6	Tx Vcc	+3.3V dc power for the transmitter section
7	TD-	See recommended circuit schematic
8	TD+	See recommended circuit schematic
9	Tx GND	Directly connect this pin to the transmitter ground plane

RECOMMENDED CIRCUIT SCHEMATIC

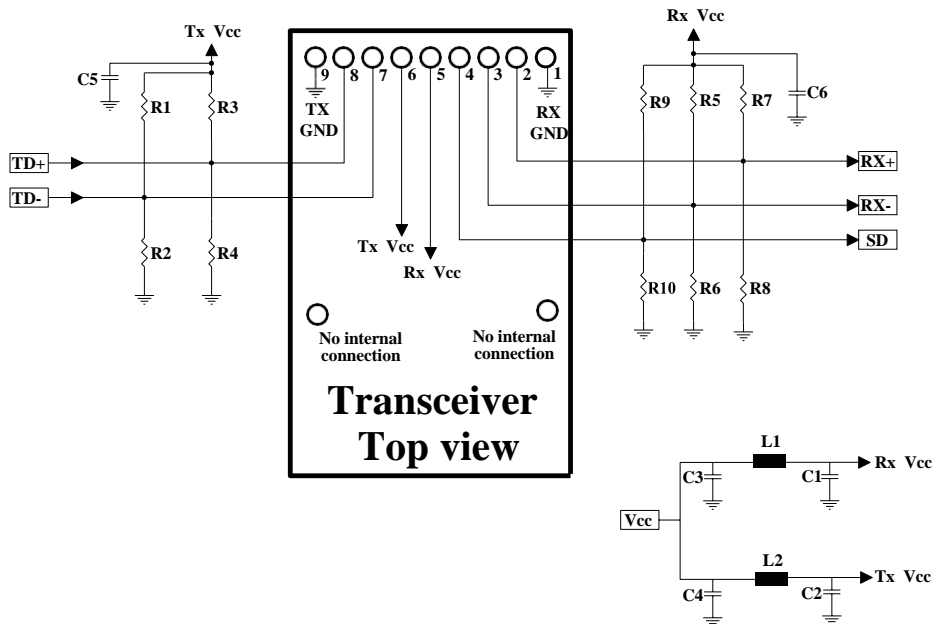

R1=R3=R5=R7=R9=130 ohm
 R2=R4=R6=R8=R10=82 ohm
 C1=C2=C3=C5=C6=0.1 Uf
 C4=10uF L1=L2=1uH

Professional high-speed optical transceiver

The split-load terminations for ECL signals need to be located at the input of devices receiving those ECL signals. The power supply filtering is required for good EMI performance. Use short tracks from the inductor L1/L2 to the module Rx Vcc and Tx Vcc. A GND plane under the module is required for good EMI and sensitivity performance.

PACKAGE DIAGRAM

Units in mm

1) Receptacle Type

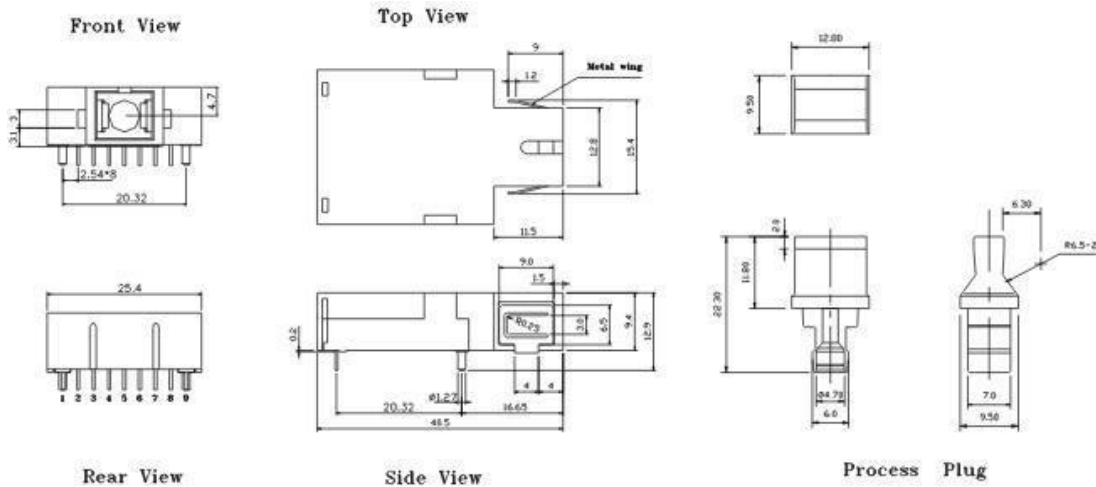

OPN-S8F1513-20SC / OPN-S8F1513-20SCI

2) Pigtail Type

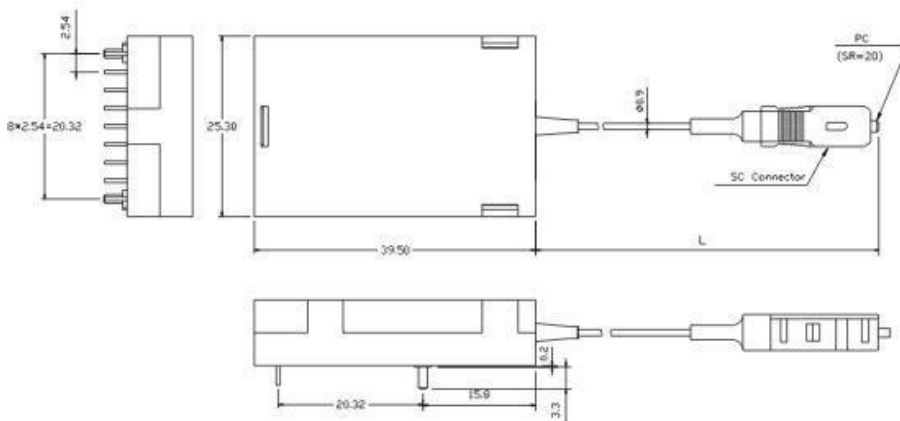

OPN-S8F1513P-20SC / OPN-S8F1513P-20SCI

Note: Length L is 50±3 cm. Other pigtail’s length is available upon request.

Note: Specifications subject to change without notice.